

# WATER DESCALERS

Water Wizard  
Water Magic  
Water Heavy Duty  
Water Heavy Duty +

MANUAL



[www.water-descaler.com](http://www.water-descaler.com)  
[www.electrostoreonline.com](http://www.electrostoreonline.com)

## MANUAL

### Introduction

The Water Descaler is a complete self-monitoring water conditioning system.

It can be installed easily without any special qualifications and minimal DIY skills. There is no plumbing required, as the existing pipe-work does not get disturbed.

For power, the Control Unit is simply plugged into a regular power outlet.

Once switched on, no further attention is required, there are no chemicals required, and with no moving parts, there is nothing to wear out.

### PRODUCT CONTENTS

- Electronic Conditioner Unit
- Antenna lead(s) (plug each end) \*
- Power Adaptor with approx. 1.8m lead (extension lead can be supplied at extra charge)
- Fixings (adhesive pads or screws)
- Two cable ties per antenna

\*  
Water Wizard uses 1 antenna  
Water Magic uses 1 antenna  
Water Heavy Duty uses 2 antennae  
Water Heavy Duty + uses 4 antennae

The standard antenna lead length is 2m long, however 5m extended lead can be supplied at extra charge.

### OPERATING

After installation, there is nothing to do, other than occasionally checking the LED display to confirm that everything is working normally. There is no routine maintenance required.

### WARNING

For safety, it is important that the electronic unit never gets wet or is regularly in a damp atmosphere or experiences condensation.

## OPERATION MANUAL

### Installation

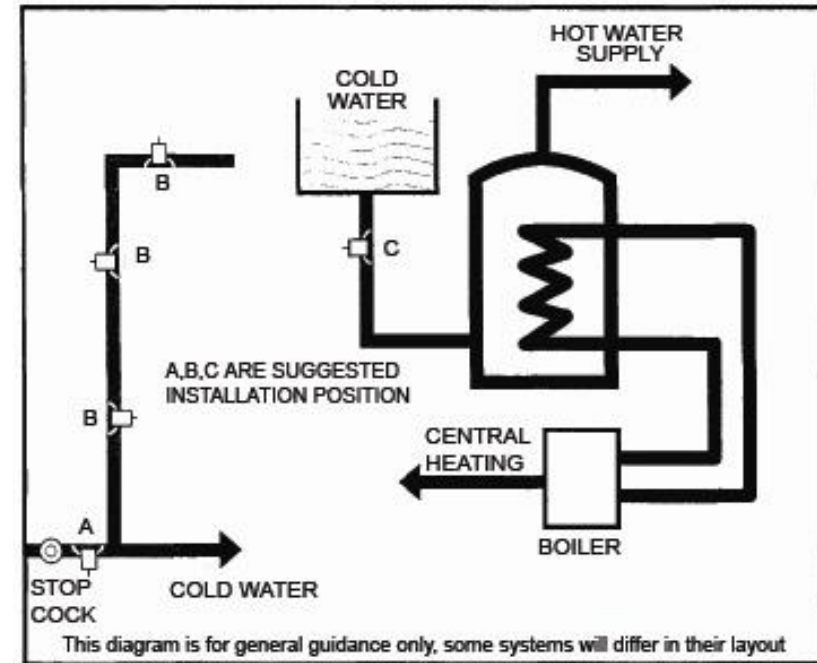

### Water Wizard, Water Magic (1 antenna)

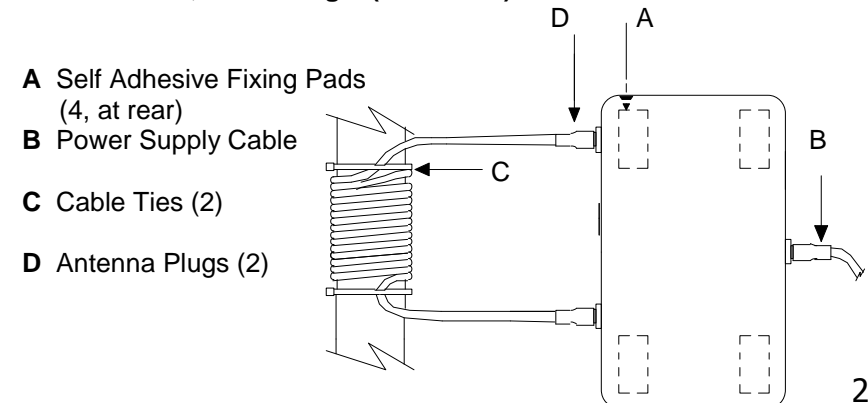

## OPERATION MANUAL

### Installation Instructions

1. Check "Contents" above.
2. Check the power adaptor matches local supply voltage. It will be either "115" (110/120) or "230" (220/240) volts AC.
3. Refer to the diagrams below. Select the diagram that applies to your chosen model of descaler.

#### ELECTRONIC UNIT

4. Choose a location where 100mm length of pipe is accessible (ideally close to the incoming water main / stop tap / meter, and before any branches in the pipe).
5. A mains power outlet is required. If there is no socket within 1.8m (6 feet) then extension lead can be supplied.
6. The area must be dry, and not susceptible to frost or condensation.
7. Mount the electronic control unit securely on the wall adjacent to the pipe using only the external feet, and preferably above the pipe in case of condensation dripping from the pipe. **DO NOT OPEN THE CONTROL UNIT.**

#### ANTENNA

8. Wrap the antenna tightly around the pipe with a minimum of 12 turns, and secure using cable ties provided. Note that the antenna must remain tight to be effective.
9. The 2 plugs plug into the electronic unit. The 2 plugs for an antenna are interchangeable, but for systems with more than 1 antenna, it is important to keep them in pairs.
10. Note: if the plumbing is iron or lead, then a copper or plastic section must be inserted for the conditioner to be effective.

#### POWER ADAPTOR

11. If the rated supply voltage matches the local supply, then plug the electronic unit into the supply outlet.

## OPERATION MANUAL

### Installation Diagrams

#### Water Heavy Duty (2 antennae)

- A Screw Fixings (4)
- B Power Supply Plug
- C 50mm Centre Gap (between coils)
- D Cable Ties (4)
- E Antenna Plugs (4)

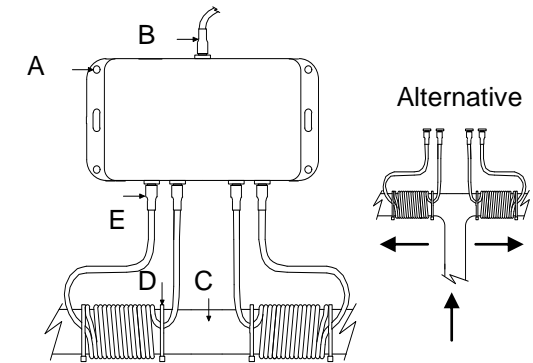

#### Water Heavy Duty + (4 antennae)

- A Screw Fixings (4)
- B Power Supply Plug
- C 50mm Gap
- D Cable Ties (8)
- E Antenna Plugs (8)

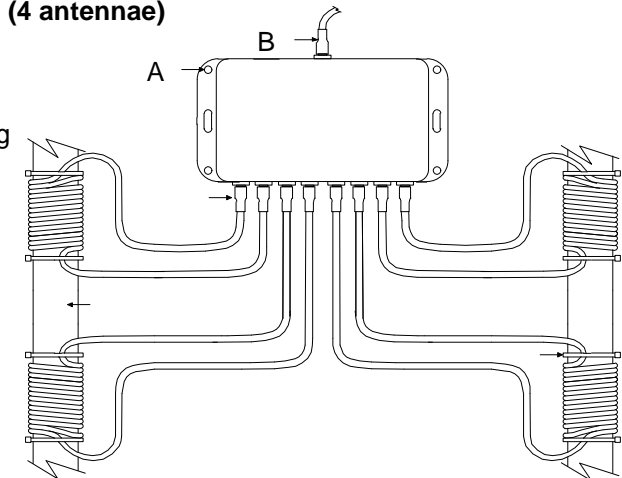

## OPERATION MANUAL

### Running the System

On supplying power, the system will automatically start working. If there are no LED lamps lit, then check the power connections.

A red LED indicates that power is present (note: Water Wizard does not have a separate red LED).

**THERE ARE HAZARDOUS VOLTAGES INSIDE THE POWER ADAPTOR, DO NOT ATTEMPT TO OPEN IT, AND DO NOT PLUG IT IN IF IT APPEARS DAMAGED.**

Green LEDs indicate operation. For the first few seconds the LEDs will flash while the computer inside checks the system is operating, and then it will settle into a regular pattern to confirm normal conditioning.

#### CORRECT OPERATION:

*Water Wizard, Water Magic:* The 4 green LEDs will flash in turn.

*Heavy Duty, Heavy Duty +:* Both green LEDs are independently flashing.

#### FAULT DETECTED:

*Water Wizard, Water Magic:* No flashing, centre two LEDs lit indicates an antenna fault.

*Heavy Duty:* One or both LEDs will be not flashing. Check all antennae.

If the system appears not to be working, especially if the red LED is off, check the power supply is live, and check supply fuses, RCDs etc.

Note: if the supply has a fuse fitted, it must only be replaced by one of identical type and current rating.

Note: there are no hazardous voltages present on the antenna.

## OPERATION MANUAL

### Water Conditioning

#### EFFECTIVENESS

Assuming the model of conditioner acquired is a good match to the size of property and water usage, then the effectiveness depends on the degree of water hardness. It can take two to three months to become fully effective and if scale is already strongly established the effects will not be obvious for a while.

#### SPEED OF OPERATION

The conditioner will be immediately effective at reforming the calcium carbonate that causes lime scale deposit. This means that further deterioration in the plumbing should be slowed or stopped. Note that unless the entire system is drained first, there will be some delay before treated water reaches all taps etc. depending on water usage. If any pipes are already blocked, they may have to be replaced first to allow any flow to take place.

Any existing lime scale deposit that is removed may cause the water to become cloudy temporarily; this is normal.

Existing lime scale deposits should now be under control and should even decrease by dissolving in the conditioned water, however this process will be slow since it is reversing a process that may have taken years to build up.

The conditioning effect persists in the treated water unless it is boiled. For this reason kettles may still suffer from lime scale build-up if they are left with boiled water in them. To reduce this, boiled water should be poured away, and the kettle refilled with fresh cold water (subject to the manufacturers guidelines).

## OPERATION MANUAL

### Technical Information

The exact specification may alter, so these figures are approximate.

- Antenna:** 1 to 4 depending on model...  
Water Wizard and Water Magic: 1  
Water Heavy Duty: 2  
Water Heavy Duty +: 4
- Power Supply:** Either 230V(220/240) 50Hz or 115V(110/120) 60Hz, depending on version purchased.
- Power Connectors:** 1 of the following must be specified: UK, Euro, USA.
- Power Consumption:** 2 to 9 watts depending on model.
- Dimensions:** Control Unit case sizes (not including power adaptor):  
Water Wizard and Water Magic: 120 x 80 x 40mm.  
Heavy Duty models: 200 x 125 x 60mm.
- Weights:** Water Wizard, Water Magic: 100g (Control Unit)  
Water Heavy Duty: 280g (Control Unit)  
Water Heavy Duty +: 300g (Control Unit)  
Power Adaptor: 250g
- Mounting:** Screws or self-adhesive pads can be used.  
Water Wizard and Water Magic are supplied with self-adhesive pads fitted, the Heavy Duty models are supplied with screws.
- Climate:** The Control Unit works within 0-70 °C,  
90% maximum RH, no condensation.
- System Self Test:** Continuous, including antenna integrity test.

## OPERATION MANUAL

### Guarantee

This product is guaranteed against manufacturing defects (labour or material) for 1 year from the date of purchase, under normal usage. The product when purchased directly from electrostoreonline web site entitles you to a total of 3 years extended manufacturing guarantee and 90 days no-quibble money back guarantee.

**"90 DAYS NO-QUIBBLE MONEY BACK GUARATEE"**, if you are not satisfied with the results of the scale removal and prevention after 90 days from installation, you may return your unit for a full rebate.

The guarantee DOES NOT APPLY in case of improper use, accidental damage, negligence or lack of maintenance to the unit. If the unit fails due to a manufacturing fault within the Guarantee period it will be either repaired or replaced free of charge. Liability is limited to replacement of the faulty product only; no other costs will be reimbursed.

This guarantee does not affect your statutory rights and cannot be transferred. This guarantee does not confer any rights other than those expressly set out above.

Contact us for more details:  
ELECTROSTOREONLINE  
Beechwood House  
Falkland Close  
Coventry CV4 8HQ  
Tel: +44(0) 2476 466277  
Fax: +44(0) 2476 465298  
www.water-descaler.com  
www.electrostoreonline.com  
Email: [sales@electrostoreonline.com](mailto:sales@electrostoreonline.com)



WDM0410